

OPTICAL TAPS FOR RURAL FTTX NETWORKS

SITUATION

When deploying a Passive Optical Networking (PON) system in a rural area the low subscriber density and long feeder fiber span length make using 1xN optical splitters difficult. In more dense areas where the feeder fiber spans tend to be shorter it is much easier to fully realize the efficiencies of a PON network.

SOLUTION

By utilizing an optical tap architecture, you can control the optical budget sending the optical power where you need it. This allows you to serve longer spans, have more drop nodes along the route, eliminate the need of expensive splitter cabinets and leverage existing fiber cables by serving up to 60+ customers on a single fiber strand. Optical taps work by splitting the incoming signal in two paths, the drop path and the thru path. Unlike with 1xN splitters, that would split the optical signal into equal parts, the tap splits the signal into two unbalanced paths. For example, at the node closest to the OLT you could deploy a tap with an 60/40 split ratio that sends 60% of the incoming optical power to the thru port down the feeder fiber. The remaining 40% of the incoming optical power will be sent to the drop port to feed a branch fiber or short drop run. See Figure 1 below for a logical diagram of a tap architecture.

Additionally, optical taps can be combined with splitters. Rather than having a single drop port at the tap node you could have 2, 4, or even 8 drop ports to serve subscribers local to the node.

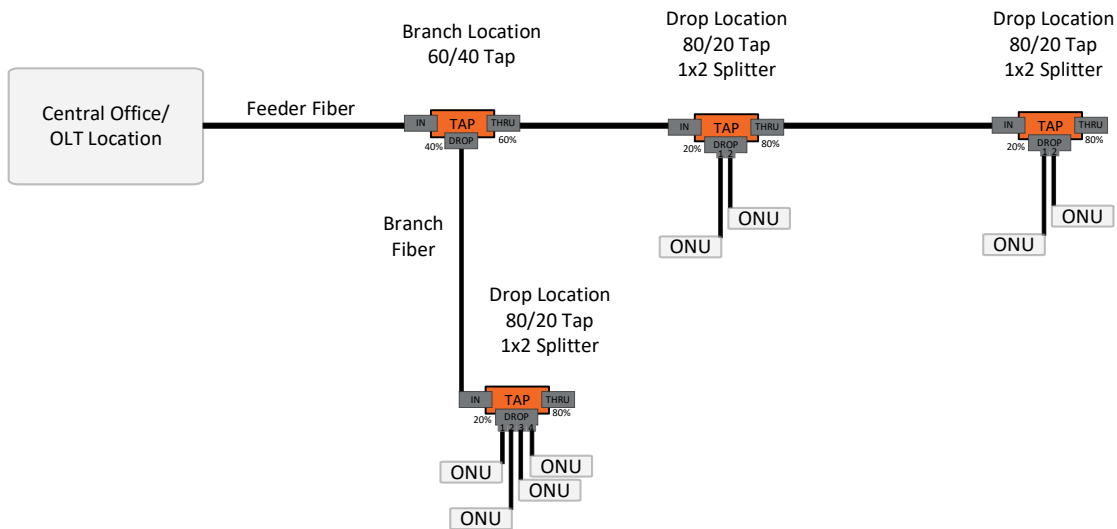

FIGURE 1: FTTH PON NETWORK USING TAPS AND SPLITTER-TAP MODULES

FEATURES

- Serve 60+ Subscribers Using One Fiber
- Eliminate Splice Cabinets
- Many Split Ratios
- 2 Form Factors Available
- Factory or Field Connectorized Options

ENVIRONMENT

- Central Office/ Headend
- Buried / Aerial
- Customer Premise
- Campus / MDU
- Industrial / Construction

APPLICATIONS

- Fiber-To-The-Home
- Fiber-To-The-Tower
- SMB & Enterprise
- Rural Utility
- Smart City

The UBM-T series of optical taps are an ideal solution for deploy “anywhere” applications where factory connectorized splitters are desired. Featuring a small form factor and universal mounting brackets, the UBM-T modules, available in many split ratios, can handle most applications.



UBM-T RATIO TAP MODULE

ORDERING INFORMATION				
PART NUMBER	DESCRIPTION	THRU LOSS (dB)	TAP LOSS (dB)	
PLO-U-T9901-SCA-SCA	1X2 UBM-T-21, 1X2 COUPLER, 21DB TAP VALUE, SC/APC	0.63	20.50	
PLO-U-T9802-SCA-SCA	1X2 UBM-T-18, 1X2 COUPLER, 18DB TAP VALUE, SC/APC	0.70	17.60	
PLO-U-T9703-SCA-SCA	1X2 UBM-T-17, 1X2 COUPLER, 17DB TAP VALUE, SC/APC	0.73	15.80	
PLO-U-T9505-SCA-SCA	1X2 UBM-T-15, 1X2 COUPLER, 15DB TAP VALUE, SC/APC	0.80	13.60	
PLO-U-T9307-SCA-SCA	1X2 UBM-T-13, 1X2 COUPLER, 13DB TAP VALUE, SC/APC	1.00	11.70	
PLO-U-T9010-SCA-SCA	1X2 UBM-T-11, 1X2 COUPLER, 11DB TAP VALUE, SC/APC	1.10	10.60	
PLO-U-T8515-SCA-SCA	1X2 UBM-T-10, 1X2 COUPLER, 10DB TAP VALUE, SC/APC	1.30	8.80	
PLO-U-T8020-SCA-SCA	1X2 UBM-T-8, 1X2 COUPLER, 8DB TAP VALUE, SC/APC	1.60	7.60	
PLO-U-T7030-SCA-SCA	1X2 UBM-T-6, 1X2 COUPLER, 6DB TAP VALUE, SC/APC	2.15	5.80	
PLO-U-T6040-SCA-SCA	1X2 UBM-T-5, 1X2 COUPLER, 5DB TAP VALUE, SC/APC	2.80	4.60	
PLO-U-T4555-SCA-SCA	1X2 UBM-T-3, 1X2 COUPLER, 3DB TAP VALUE, SC/APC	4.22	3.25	
PLO-U-T3070-SCA-SCA	1X2 UBM-T-2, 1X2 COUPLER, 2DB TAP VALUE, SC/APC	5.80	2.15	

NOTE: SPLITTER ONLY AND SPLITTER-TAP COMBO MODULES ARE ALSO AVAILABLE.

The USBM-T series of optical tap-splitters combine the versatility of optical taps with the customer drop fiber ports needed to service subscribers from the same location.



USBM-T 1x2 SPLITTER-TAP MODULE



USBM-T 1x4 SPLITTER-TAP MODULE



USBM-T 1x8 SPLITTER-TAP MODULE

ORDERING INFORMATION

PART NUMBER	DESCRIPTION	THRU LOSS (dB)	TAP LOSS (dB)
PLO-U-102-T9703-SCA-SCA	1x2 USBM-T-21, 1x2 PLC Splitter, 21dB Tap Value, SC/APC	0.73	19.3
PLO-U-102-T9505-SCA-SCA	1x2 USBM-T-19, 1x2 PLC Splitter, 19dB Tap Value, SC/APC	0.8	17.1
PLO-U-102-T9307-SCA-SCA	1x2 USBM-T-17, 1x2 PLC Splitter, 17dB Tap Value, SC/APC	0.8	15.2
PLO-U-102-T9010-SCA-SCA	1x2 USBM-T-15, 1x2 PLC Splitter, 15dB Tap Value, SC/APC	1.1	14.1
PLO-U-102-T8515-SCA-SCA	1x2 USBM-T-14, 1x2 PLC Splitter, 14dB Tap Value, SC/APC	1.3	12.3
PLO-U-102-T8020-SCA-SCA	1x2 USBM-T-12, 1x2 PLC Splitter, 12dB Tap Value, SC/APC	1.6	11.1
PLO-U-102-T7030-SCA-SCA	1x2 USBM-T-10, 1x2 PLC Splitter, 10dB Tap Value, SC/APC	2.15	9.3
PLO-U-102-T6040-SCA-SCA	1x2 USBM-T-8, 1x2 PLC Splitter, 8dB Tap Value, SC/APC	2.8	8.1
PLO-U-102-T4555-SCA-SCA	1x2 USBM-T-7, 1x2 PLC Splitter, 7dB Tap Value, SC/APC	4.4	6.8
PLO-U-102-T3070-SCA-SCA	1x2 USBM-T-5, 1x2 PLC Splitter, 5dB Tap Value, SC/APC	5.8	5.8
PLO-U-102-SCA-SCA	1x2 USBM, 1x2 PLC Splitter, SC/APC	T	4.0

NOTE: SPLITTER ONLY AND TAP ONLY MODULES ARE ALSO AVAILABLE.

ORDERING INFORMATION (CONTINUED)

PART NUMBER	DESCRIPTION	THRU LOSS (dB)	TAP LOSS (dB)
PLO-U-104-T9307-SCA-SCA	1x4 USBM-T-21, 1x4 PLC Splitter, 21dB Tap Value, SC/APC	0.8	18.6
PLO-U-104-T9010-SCA-SCA	1x4 USBM-T-19, 1x4 PLC Splitter, 19dB Tap Value, SC/APC	1.1	17.5
PLO-U-104-T8515-SCA-SCA	1x4 USBM-T-17, 1x4 PLC Splitter, 17dB Tap Value, SC/APC	1.3	15.7
PLO-U-104-T8020-SCA-SCA	1x4 USBM-T-15, 1x4 PLC Splitter, 15dB Tap Value, SC/APC	1.6	14.5
PLO-U-104-T7030-SCA-SCA	1x4 USBM-T-13, 1x4 PLC Splitter, 13dB Tap Value, SC/APC	2.15	12.7
PLO-U-104-T6040-SCA-SCA	1x4 USBM-T-11, 1x4 PLC Splitter, 11dB Tap Value, SC/APC	2.8	11.5
PLO-U-104-T4555-SCA-SCA	1x4 USBM-T-10, 1x4 PLC Splitter, 10dB Tap Value, SC/APC	4.4	10.2
PLO-U-104-T3070-SCA-SCA	1x4 USBM-T-9, 1x4 PLC Splitter, 9dB Tap Value, SC/APC	5.8	9.2
PLO-U-104-SCA-SCA	1x4 USBM, 1x4 PLC Splitter, SC/APC	T	7.4

ORDERING INFORMATION (CONTINUED)

PART NUMBER	DESCRIPTION	THRU LOSS (dB)	TAP LOSS (dB)
PLO-U-108-T9010-SCA-SCA	1x8 USBM-T-21, 1x8 PLC Splitter, 21dB Tap Value, SC/APC	1.1	20.4
PLO-U-108-T8515-SCA-SCA	1x8 USBM-T-19, 1x8 PLC Splitter, 19dB Tap Value, SC/APC	1.3	18.6
PLO-U-108-T8020-SCA-SCA	1x8 USBM-T-17, 1x8 PLC Splitter, 17dB Tap Value, SC/APC	1.6	17.4
PLO-U-108-T7030-SCA-SCA	1x8 USBM-T-16, 1x8 PLC Splitter, 16dB Tap Value, SC/APC	2.15	15.6
PLO-U-108-T6040-SCA-SCA	1x8 USBM-T-15, 1x8 PLC Splitter, 15dB Tap Value, SC/APC	2.8	14.4
PLO-U-108-T4555-SCA-SCA	1x8 USBM-T-14, 1x8 PLC Splitter, 14dB Tap Value, SC/APC	4.4	13.1
PLO-U-108-T3070-SCA-SCA	1x8 USBM-T-12, 1x8 PLC Splitter, 12dB Tap Value, SC/APC	5.9	12.1
PLO-U-108-SCA-SCA	1x8 USBM, 1x8 PLC Splitter, SC/APC	T	10.7

Plugin Optics offers a complete range of bare fiber ratio fused tap couplers. This line of FTC taps are ideal for “splice-in” or field connectorized applications. These carrier grade taps offer the best balance between cost and flexibility for any network operator who needs to reduce insertion loss in the ODN tap architecture.



ORDERING INFORMATION

PART NUMBER	DESCRIPTION	THRU LOSS (dB)	TAP LOSS (dB)
PLO-FTC-5050-1-25-0	1X2, DUAL WINDOW, FUSED TAP COUPLER, 50/50, 0.25MM PIGTAIL DIAMETER, SINGLE MODE FIBER, 2.5M PIGTAILS, NO CONNECTOR	3.7	3.7
PLO-FTC-5545-1-25-0	1X2, DUAL WINDOW, FUSED TAP COUPLER, 55/45, 0.25MM PIGTAIL DIAMETER, SINGLE MODE FIBER, 2.5M PIGTAILS, NO CONNECTOR	3.2	4.1
PLO-FTC-6040-1-25-0	1X2, DUAL WINDOW, FUSED TAP COUPLER, 60/40, 0.25MM PIGTAIL DIAMETER, SINGLE MODE FIBER, 2.5M PIGTAILS, NO CONNECTOR	2.7	4.7
PLO-FTC-6535-1-25-0	1X2, DUAL WINDOW, FUSED TAP COUPLER, 65/35, 0.25MM PIGTAIL DIAMETER, SINGLE MODE FIBER, 2.5M PIGTAILS, NO CONNECTOR	2.3	5.3
PLO-FTC-7030-1-25-0	1X2, DUAL WINDOW, FUSED TAP COUPLER, 70/30, 0.25MM PIGTAIL DIAMETER, SINGLE MODE FIBER, 2.5M PIGTAILS, NO CONNECTOR	2.0	6.0
PLO-FTC-7525-1-25-0	1X2, DUAL WINDOW, FUSED TAP COUPLER, 75/25, 0.25MM PIGTAIL DIAMETER, SINGLE MODE FIBER, 2.5M PIGTAILS, NO CONNECTOR	1.6	6.8
PLO-FTC-8020-1-25-0	1X2, DUAL WINDOW, FUSED TAP COUPLER, 80/20, 0.25MM PIGTAIL DIAMETER, SINGLE MODE FIBER, 2.5M PIGTAILS, NO CONNECTOR	1.3	7.8
PLO-FTC-8515-1-25-0	1X2, DUAL WINDOW, FUSED TAP COUPLER, 85/15, 0.25MM PIGTAIL DIAMETER, SINGLE MODE FIBER, 2.5M PIGTAILS, NO CONNECTOR	1.0	9.2
PLO-FTC-9010-1-25-0	1X2, DUAL WINDOW, FUSED TAP COUPLER, 90/10, 0.25MM PIGTAIL DIAMETER, SINGLE MODE FIBER, 2.5M PIGTAILS, NO CONNECTOR	0.8	11.2
PLO-FTC-9307-1-25-0	1X2, DUAL WINDOW, FUSED TAP COUPLER, 93/07, 0.25MM PIGTAIL DIAMETER, SINGLE MODE FIBER, 2.5M PIGTAILS, NO CONNECTOR	0.7	13.5
PLO-FTC-9505-1-25-0	1X2, DUAL WINDOW, FUSED TAP COUPLER, 95/05, 0.25MM PIGTAIL DIAMETER, SINGLE MODE FIBER, 2.5M PIGTAILS, NO CONNECTOR	0.5	14.4
PLO-FTC-9703-1-25-0	1X2, DUAL WINDOW, FUSED TAP COUPLER, 97/03, 0.25MM PIGTAIL DIAMETER, SINGLE MODE FIBER, 2.5M PIGTAILS, NO CONNECTOR	0.4	17.0
PLO-FTC-9802-1-25-0	1X2, DUAL WINDOW, FUSED TAP COUPLER, 98/02, 0.25MM PIGTAIL DIAMETER, SINGLE MODE FIBER, 2.5M PIGTAILS, NO CONNECTOR	0.35	17.8
PLO-FTC-9901-1-25-0	1X2, DUAL WINDOW, FUSED TAP COUPLER, 99/01, 0.25MM PIGTAIL DIAMETER, SINGLE MODE FIBER, 2.5M PIGTAILS, NO CONNECTOR	0.3	21.5

NOTE: FIBER TAP COUPLERS CAN BE ORDERED IN MULTIPLE CONFIGURATIONS. PLEASE CONTACT US FOR CONNECTOR OR SPLICE TRAY APPLICATIONS.